



CONTAINER COD. 019053

CLOSING SYSTEM

Heat-sealable film

RAW MATERIAL

PP - Polypropylene for food



LABELING:

IML

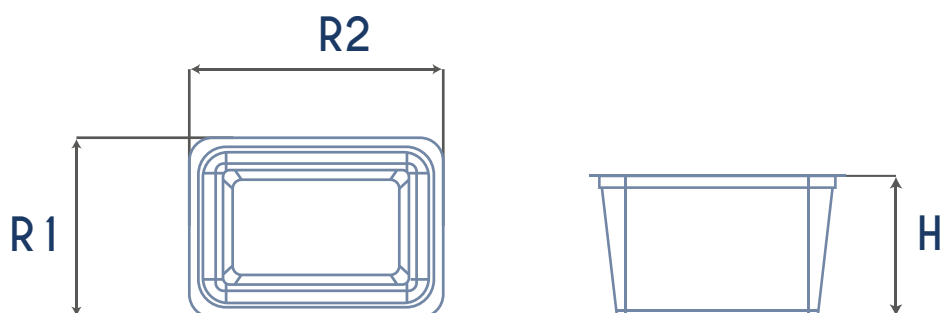

R1	R2	H*	ITEM WEIGHT	VOLUME
104,0 mm (+/- 1%)	156,0 mm (+/- 1%)	60,0 mm (+/- 1%)	19,0 gr (+/- 5%)	0,60 lt (+/-5%)

*height without lid

CARTON BOX	
SIZE	79,0x38,5x33,5h cm
PIECES	782
GROSS WEIGHT*	16,0 kg

*includes packaging, bag, tape weight

PALLET	
MISURA	80x120x205h cm
TOT. BOX	18
TOT. PIECES	14.076
GROSS WEIGHT*	310 kg

*includes weight of each carton, extendable film, weight of the platform etc.

N.B: prolonged storage for over 6 months at room temperature, including heating up to 70°C for a duration of up to 2 hours or heating up to 100°C for a duration of up to 15 minutes